



Performance Rated I-Joists

DESIGN/CONSTRUCTION GUIDE



WOOD

The Natural Choice



Engineered wood products are a good choice for the environment. They are manufactured for years of trouble-free, dependable use. They help reduce waste by decreasing disposal costs and product damage. Wood is a renewable resource that is easily manufactured into a variety of viable products.

A few facts about wood.

- *We're growing more wood every day.* Forests fully cover one-third of the United States' and one-half of Canada's land mass. American landowners plant more than two billion trees every year. In addition, millions of trees seed naturally. The forest products industry, which comprises about 15 percent of forestland ownership, is responsible for 41 percent of replanted forest acreage. That works out to more than one billion trees a year, or about three million trees planted every day. This high rate of replanting accounts for the fact that each year, 27 percent more timber is grown than is harvested. Canada's replanting record shows a fourfold increase in the number of trees planted between 1975 and 1990.



- *Life Cycle Assessment shows wood is the greenest building product.* A 2004 Consortium for Research on Renewable Industrial Materials (CORRIM) study gave scientific validation to the strength of wood as a green building product. In examining building products' life cycles – from extraction of the raw material to demolition of the building at the end of its long lifespan – CORRIM found that wood was better for the environment than steel or concrete in terms of embodied energy, global warming potential, air emissions, water emissions and solid waste production. For the complete details of the report, visit www.CORRIM.org.

- *Manufacturing wood is energy efficient.* Wood products made up 47 percent of all industrial raw materials manufactured in the United States, yet consumed only 4 percent of the energy needed to manufacture all industrial raw materials, according to a 1987 study.

Material	Percent of Production	Percent of Energy Use
Wood	47	4
Steel	23	48
Aluminum	2	8



- *Good news for a healthy planet.* For every ton of wood grown, a young forest produces 1.07 tons of oxygen and absorbs 1.47 tons of carbon dioxide.

Wood: It's the natural choice for the environment, for design and for strong, lasting construction.

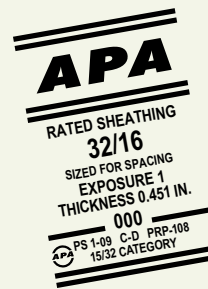

NOTICE:
 The recommendations in this guide apply only to products that bear the APA trademark. Only products bearing the APA trademark are subject to the Association's quality auditing program.

APA PERFORMANCE RATED™ I-JOISTS PROVIDE QUALITY CHOICE FOR RESIDENTIAL FLOORS

APA Performance Rated I-joists (PRI™) provide a high-performance alternative to dimension lumber joists for residential floor applications. This guide will help you use APA PRIs efficiently by walking you through the simple steps of product selection, specification and installation.

The APA EWS trademark signifies that the I-joist manufacturer is committed to the strict quality standards of APA, and that PRIs are manufactured in conformance with PRI-400, *Performance Standard for APA EWS I-joists*. APA's rigorous program of quality verification and testing is designed to assure consistent and reliable product performance.

PRI-400 brings product standardization while providing for a multitude of design and construction situations. The standard provides design information for numerous types and sizes of I-joists. Now specifiers and builders can select and use I-joists from various APA member manufacturers, using just one set of design and installation criteria. Because PRIs can be selected based on their allowable span for uniformly loaded glue-nailed residential floors, it is easy to incorporate them into your design.

While this guide emphasizes residential floor systems, much of the basic design information can be used for other construction applications. Review by a design professional is required for applications beyond the scope of this document. (See Table 8 for design properties.)

Simple to specify. Easy to install. APA Performance Rated I-joists are the right choice for residential floor construction.



SELECTING APA PERFORMANCE RATED I-JOISTS

Product Description

The APA Performance Rated I-joist (PRI) is an “T”-shaped engineered wood structural member designed for use in residential floor construction. The product is prefabricated using sawn or structural composite lumber flanges and wood structural panel webs, bonded together with exterior-type adhesives. In order to be classified as an APA PRI, the joist is limited to a L/480 live load maximum deflection (where L = span) for glue-nailed residential floor applications, a criteria which provides superior floor performance.

TABLE 1

ALLOWABLE SPANS FOR APA EWS PERFORMANCE-RATED I-JOISTS – SIMPLE SPAN ONLY^(a,b,c,d)

Depth	Joist Series	Simple Spans			
		On Center Spacing			
		12"	16"	19.2"	24"
9'-1/2"	PRI-20	16'-2"	14'-10"	14'-0"	13'-1"
	PRI-30	17'-1"	15'-7"	14'-9"	13'-9"
	PRI-40	17'-9"	16'-3"	15'-4"	14'-4"
	PRI-50	17'-10"	16'-4"	15'-5"	14'-5"
	PRI-60	18'-8"	17'-1"	16'-1"	15'-0"
11'-7/8"	PRI-20	19'-3"	17'-8"	16'-8"	15'-7"
	PRI-30	20'-4"	18'-7"	17'-7"	16'-5"
	PRI-40	21'-2"	19'-4"	18'-3"	16'-8"
	PRI-50	21'-2"	19'-5"	18'-4"	17'-1"
	PRI-60	22'-2"	20'-3"	19'-2"	17'-10"
	PRI-70	23'-0"	20'-11"	19'-9"	18'-5"
	PRI-80	24'-6"	22'-4"	21'-0"	19'-7"
	PRI-90	25'-2"	22'-11"	21'-8"	20'-2"
14"	PRI-40	24'-0"	21'-11"	20'-6"	18'-4"
	PRI-50	24'-1"	22'-0"	20'-9"	19'-5"
	PRI-60	25'-2"	23'-0"	21'-9"	20'-3"
	PRI-70	26'-1"	23'-9"	22'-5"	20'-11"
	PRI-80	27'-9"	25'-4"	23'-10"	22'-2"
PRI-90	28'-7"	26'-0"	24'-6"	22'-10"	
16"	PRI-40	26'-7"	24'-3"	22'-1"	19'-9"
	PRI-50	26'-8"	24'-4"	23'-0"	20'-2"
	PRI-60	27'-11"	25'-6"	24'-0"	22'-5"
	PRI-70	28'-10"	26'-4"	24'-10"	23'-1"
	PRI-80	30'-9"	28'-0"	26'-5"	24'-7"
PRI-90	31'-7"	28'-9"	27'-1"	25'-3"	

Notes:

- (a) Allowable **clear** span applicable to simple-span residential floor construction with a design dead load of 10 psf and live load of 40 psf. The live load deflection is limited to span/480.
- (b) Spans are based on a composite floor with glued-nailed sheathing meeting the requirements for APA Rated Sheathing or APA Rated STURD-I-FLOOR conforming to PS 1, PS 2, CSA O325, or CSA O437 with a minimum 19/32 Performance Category (40/20 or 20 oc) for a joist spacing of 19.2 inches or less, or 23/32 Performance Category (48/24 or 24 oc) for a joist spacing of 24 inches. Adhesive shall meet ASTM D3498 or APA Specification AFG-01. Spans shall be reduced 12 inches when the floor sheathing is nailed only.
- (c) Minimum bearing length shall be 1-3/4 inches for the end bearings.
- (d) Bearing stiffeners are not required when I-joists are used with the spans and spacings given in this table, except as required by hanger manufacturers.

TABLE 2

ALLOWABLE SPANS FOR APA EWS PERFORMANCE-RATED I-JOISTS – MULTIPLE SPAN ONLY^(a,b,c,d)

Depth	Joist Series	Multiple Spans			
		On Center Spacing			
		12"	16"	19.2"	24"
9-1/2"	PRI-20	17'-7"	16'-1"	15'-3"	13'-5"
	PRI-30	18'-7"	17'-0"	16'-0"	15'-0"
	PRI-40	19'-4"	17'-8"	16'-4"	14'-7"
	PRI-50	19'-5"	17'-9"	16'-9"	15'-7"
	PRI-60	20'-4"	18'-7"	17'-6"	16'-4"
11-7/8"	PRI-20	21'-0"	19'-2"	16'-9"	13'-5"
	PRI-30	22'-1"	20'-3"	18'-10"	15'-0"
	PRI-40	23'-0"	20'-5"	18'-7"	16'-7"
	PRI-50	23'-1"	21'-1"	19'-11"	16'-1"
	PRI-60	24'-2"	22'-1"	20'-10"	19'-5"
	PRI-70	25'-0"	22'-10"	21'-6"	18'-6"
	PRI-80	26'-8"	24'-3"	22'-11"	21'-3"
	PRI-90	27'-6"	25'-0"	23'-6"	21'-10"
14"	PRI-40	25'-11"	22'-5"	20'-5"	18'-3"
	PRI-50	26'-3"	23'-11"	20'-2"	16'-1"
	PRI-60	27'-6"	25'-1"	23'-8"	19'-9"
	PRI-70	28'-5"	25'-11"	23'-2"	18'-6"
	PRI-80	30'-3"	27'-7"	25'-11"	23'-11"
	PRI-90	31'-2"	28'-4"	26'-8"	24'-10"
16"	PRI-40	27'-11"	24'-2"	22'-0"	19'-8"
	PRI-50	29'-0"	24'-3"	20'-2"	16'-1"
	PRI-60	30'-5"	27'-9"	24'-9"	19'-9"
	PRI-70	31'-5"	27'-10"	23'-2"	18'-6"
	PRI-80	33'-6"	30'-6"	28'-9"	23'-11"
	PRI-90	34'-5"	31'-4"	29'-6"	26'-7"

Notes:

- (a) Allowable **clear** span applicable to multiple-span residential floor construction with a design dead load of 10 psf and live load of 40 psf. The end spans shall be 40% or more of the adjacent span. The live load deflection is limited to span/480.
- (b) Spans are based on a composite floor with glued-nailed sheathing meeting the requirements for APA Rated Sheathing or APA Rated STURD-I-FLOOR conforming to PS 1, PS 2, CSA O325, or CSA O437 with a minimum 19/32 Performance Category (40/20 or 20 oc) for a joist spacing of 19.2 inches or less, or 23/32 Performance Category (48/24 or 24 oc) for a joist spacing of 24 inches. Adhesive shall meet ASTM D3498 or APA Specification AFG-01. Spans shall be reduced 12 inches when the floor sheathing is nailed only.
- (c) Minimum bearing length shall be 1-3/4 inches for the end bearings and 3-1/2 inches for the intermediate bearings.
- (d) Bearing stiffeners are not required when I-joists are used with the spans and spacings given in this table, except as required by hanger manufacturers.

APA Performance Rated I-Joists are identified by their depth followed by a joist series, such as PRI-30, which has unique design properties.

APA PRIs are manufactured to strict tolerances with the following characteristics:

- **Flanges** are either sawn lumber or structural composite lumber, such as LVL. The top flange is of the same type and grade of material as the bottom flange. The net flange size depends on the joist series.
- **Webs** consist of wood structural panels, which can be plywood or OSB. All panels are classified as Exposure 1 or Exterior and are Performance Category 3/8 or greater.
- All PRIs are assembled using exterior-type, heat-durable adhesives per ASTM D2559 and D7247.
- APA PRIs are available in four depths: 9-1/2, 11-7/8, 14 and 16 inches.
- PRIs of the same depth are manufactured with various flange widths; flange width is an important design consideration when specifying hangers.
- Most plants supply I-joists to distributors and dealers in lengths up to 60 feet. These are then cut to frequently used lengths, such as from 16 to 36 feet in 2-foot increments for jobsite delivery. Check your local supplier for availability.

Residential Floor Allowable Spans

The specific PRI designation needed for your application is easily determined by selecting the span needed and then choosing the PRI that meets your span, spacing and uniform loading criteria.

Tables 1 and 2 are for simple or multiple span applications, respectively. The use of these tables will provide maximum spans for the indicated spacings and span conditions.

To illustrate the selection of an APA PRI product, assume a design simple span of 16 feet 1 inches. For architectural reasons limit the joist depth to 11-7/8 inches and joist spacing to 19.2 inches on center. From the 9-1/2- and 11-7/8-inch entries in Table 1, look down the 19.2-inch on center spacing column. For depths of 9-1/2 inches, select **9-1/2" PRI-60**, and for the 11-7/8-inch depths, notice that **any** joist series will work.

While any of the PRIs shown in Tables 1 and 2 may be available in a specific market area, availability of any PRI product should be verified prior to final product selection.

The allowable spans in the tables in this design guide indicate the allowable **clear span** for various joist spacings under typical residential uniform floor loads (40 psf live load and 10 psf dead load) for glue-nailed systems.

The spans shown in Tables 1 and 2 are based on a specified joist spacing up to 24 inches or less. In addition, floor sheathing must be field glued and nailed to the I-joist flanges to achieve the PRI allowable spans. Use of these span tables is limited to uniform load conditions and PRI floor spans shall not exceed these allowable spans. APA PRIs can be used for other applications, such as roofs, to support line loads or concentrated loads, among other load types, when properly engineered using the appropriate design properties in Table 8. Roof framing details are provided in *Performance Rated I-joist Roof Framing Details*, Form D510.

FIRE-RATED DESIGN CONSIDERATIONS

To slow or prevent the spread of fire, building codes require fire-resistant or fire-rated assemblies in certain locations, occupancies and types of buildings. There are numerous fire-rated floor-ceiling assemblies that incorporate I-joists and wood structural panels. These one-hour floor-ceiling and roof-ceiling assemblies are listed in the U.L. Fire Resistance Directory and are recognized as fire-rated constructions by building codes. Most include a layer of 5/8-inch or 1/2-inch gypsum wallboard as a fire-resistive component. These designs are illustrated in the *APA Design Guide: Fire-Rated Systems*, Form W305.

A Rim Board® can also serve as a fire barrier when it is installed in a continuous assembly on top of a wall, parallel or perpendicular to the joists. Fire-resistant Rim Board assemblies are shown in the *APA Data File: APA Rim Board in Fire-Rated Assemblies*, Form D350.

In some designs, sprinkler systems are used with APA Performance Rated I-Joists. There are a variety of sprinkler attachments that incorporate fasteners permitted by the National Fire Protection Association (NFPA), design load assumptions published by the NFPA, and published design fastener capacities. These sprinkler attachments are illustrated in the *APA Technical Note: Sprinkler Installation for APA Performance Rated I-Joists*, Form H730.

The 2015 International Residential Code (Section R302.13) requires fire protection of floor assemblies. APA System Report SR-405, *Fire Protection of Floors Constructed with Prefabricated Wood I-Joists for Compliance with the International Residential Code*, Form SR-405, offers options for fire protection of floors constructed with APA Performance Rated I-Joists.

TYPICAL FLOOR FRAMING AND CONSTRUCTION DETAILS

(See *I-Joist Construction Details*, Form D710, for roof framing and construction details)

Installation Notes:

1. Installation of APA PRIs shall be as shown in Figure 1.
2. Except for cutting to length, I-joist flanges should **never** be cut, drilled or notched.
3. Install I-joists so that top and bottom flanges are within 1/2 inch of true vertical alignment.
4. Concentrated loads should only be applied to the top surface of the top flange. Concentrated loads should not be suspended from the bottom flange with the exception of light loads, such as ceiling fans or light fixtures.
5. I-joists must be protected from the weather prior to installation.
6. I-joists must not be used in applications where they will be permanently exposed to weather, or will reach a moisture content of 16 percent or greater, such as in swimming pool or hot tub areas. They must not be installed where they will remain in direct contact with concrete or masonry.
7. End bearing length must be at least 1-3/4 inches. For multiple span joists, intermediate bearing length must be at least 3-1/2 inches.
8. Ends of floor joists shall be restrained to prevent rollover. Use APA Performance Rated Rim Board or I-joist blocking panels.
9. I-joists installed beneath bearing walls perpendicular to the joists shall have full-depth blocking panels, APA Performance Rated Rim Board, or squash blocks (cripple blocks) to transfer gravity loads from above the floor system to the wall or foundation below.
10. For I-joists installed directly beneath bearing walls parallel to the joists or used as rim board or blocking panels, the maximum allowable vertical load using a single I-joist is 2,000 plf, and 4,000 plf if double I-joists are used.
11. Continuous lateral support of the I-joist's compression flange is required to prevent rotation and buckling. In simple span uses, lateral support of the top flange is normally supplied by the floor sheathing. In multiple-span or cantilever applications, bracing of the I-joist's bottom flange is also required at interior supports of multiple-span joists, and at the end support next to the cantilever extension. The ends of all cantilever extensions must be laterally braced, as shown in Figure 3, 4, 5a or 5b.

12. Nails installed in flange face or edge shall be spaced in accordance with the applicable building code requirements or approved building plans, but should not be closer than those specified in Table 3.
13. Figure 1 details on the following pages show only I-joist-specific fastener requirements. For other fastener requirements, see the applicable building code.
14. For proper temporary bracing of wood I-joists and placement of temporary construction loads, see *APA Technical Note: Temporary Construction Loads Over I-Joist Roofs and Floors*, Form J735.

TABLE 3

RECOMMENDED CLOSEST NAIL SPACING FOR FASTENING SHEATHING TO APA EWS I-JOIST FLANGES TO MINIMIZE SPLITTING^(a)

Material	Fastener Size (diameter x length)	Flange Face Nailing ^(b)		Flange Edge Nailing ^(c)		
		End Distance (in.)	Nail Spacing (in.)	End Distance (in.)	Nail Spacing (in.)	
					Nailed to only one flange edge	Nailed to both flange edges
Lumber flange 1-1/2" thick 2-1/2" and wider	0.128" or smaller in diameter and 3-1/4" or shorter in length (8d box or sinker, 10d box or sinker, or 12d box)	2	2	2	2	4
	Greater than 0.128" up to 0.148" in diameter and 3-1/4" or shorter in length (8d common, 10d common, 12d sinker or common, or 16d sinker)	2	3	2	3	6
LVL flange 1-3/8" and thicker 1-1/2" and wider	0.128" or smaller in diameter and 3-1/4" or shorter in length (8d box or sinker, 10d box or sinker, or 12d box)	3	3 ^(d)	3	3	6
	Greater than 0.128" up to 0.148" in diameter and 3-1/4" or shorter in length (8d common, 10d common, 12d sinker or common, or 16d sinker)	3	3	3	3 ^(e)	6 ^(e)

Notes:

- (a) See figure below.
- (b) If more than one row is required, offset rows a minimum of 1/2 inch and stagger.
- (c) Closest nail spacing measured from one flange edge. Nails on opposite flange edge must be offset one-half the minimum spacing.
- (d) Closest nail spacing may be reduced to 2 inches if flange width is 1-3/4 inches or greater.
- (e) Limited to 0.131 x 2-1/2 inches (8d common) nails or smaller.

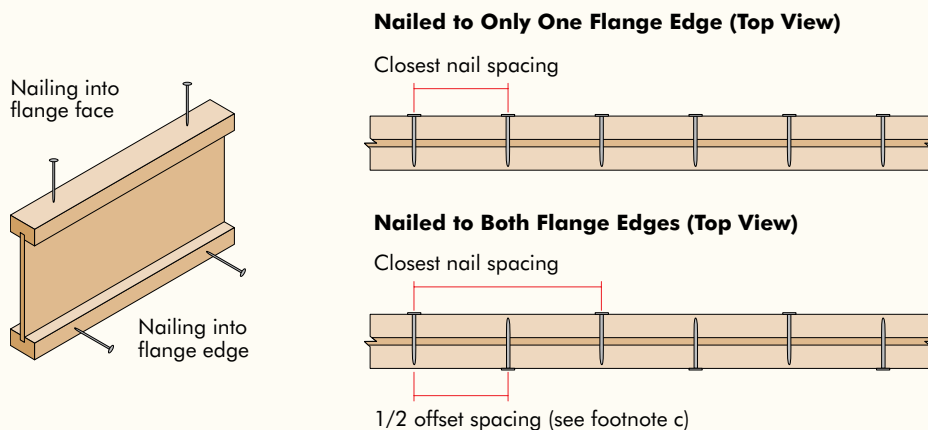

CLICK CIRCLED NUMBERS FOR DETAIL

FIGURE 1

TYPICAL PERFORMANCE RATED I-JOIST FLOOR FRAMING AND CONSTRUCTION

Some framing requirements such as erection bracing and blocking panels have been omitted for clarity.

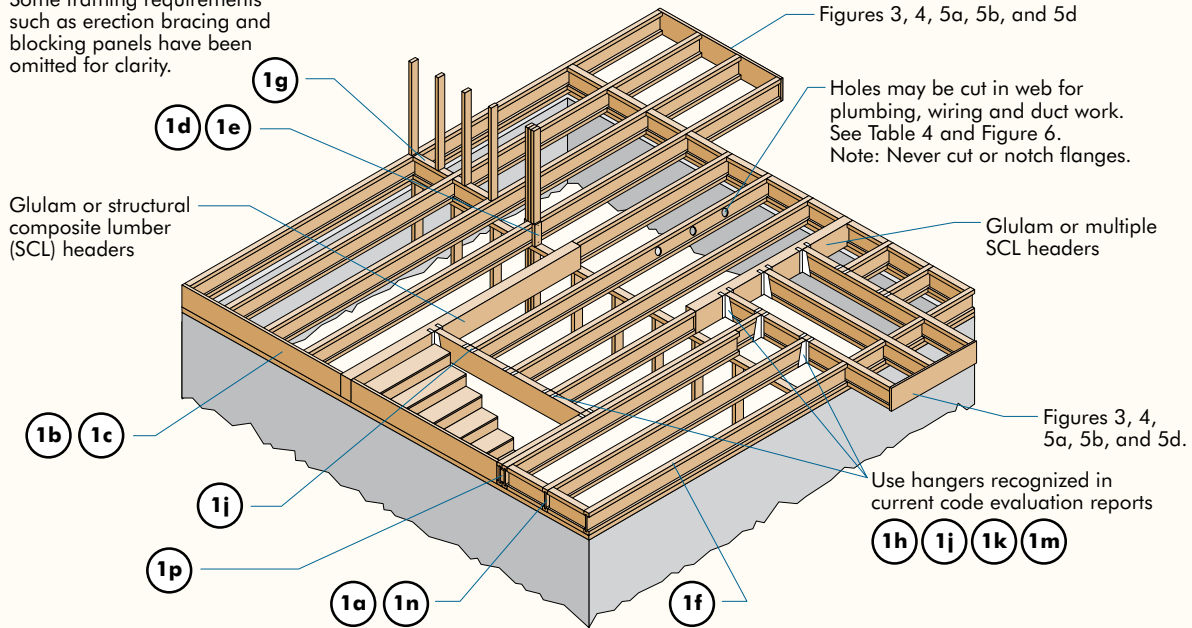

1a

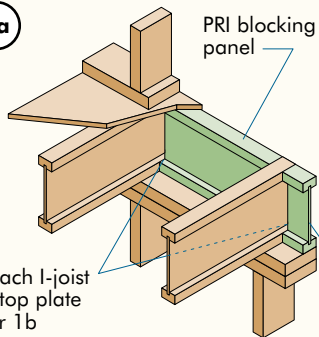

Attach I-joist to top plate per 1b

Blocking Panel or Rim Joist Uniform Vertical Load Transfer Capacity^(a) (plf)

PRI Joists	2000
------------	------

Notes:
 (a) The uniform vertical load capacity is limited to a joist depth of 16 inches or less and shall not be increased for any load duration shorter than the normal (10-yr) load duration. It shall not be used in the design of a bending member, such as joist, header, or rafter. For concentrated vertical load transfer capacity, see 1d.

8d nails at 6" o.c. to top plate (when used for lateral shear transfer, nail to bearing plate with same nailing as required for decking)

All nails shown in the details above are assumed to be common nails unless otherwise noted. 10d box nails (0.128 inch x 3 inches) may be substituted for 8d common (0.131 inch x 2-1/2 inches) shown in details. Individual components not shown to scale for clarity.

1b

Blocking Panel or Rim Joist	Uniform Vertical Load Transfer Capacity ^(a) (plf)
1-1/8" APA Rim Board Plus, B2 or better ^(b)	4850
1-1/8" APA Rim Board, C1 or better ^(b)	4400
1" APA Rim Board, C2 or better ^(b)	3300

(a) The uniform vertical load capacity is limited to a Rim Board depth of 16 inches or less and shall not be increased for any load duration shorter than the normal (10-yr) load duration. It shall not be used in the design of a bending member, such as joist, header, or rafter. For concentrated vertical load transfer capacity, see 1d.
 (b) See ANSI/APA PRR 410: *Standard for Performance-Rated Engineered Wood Rim Boards*, Form PRR-410.

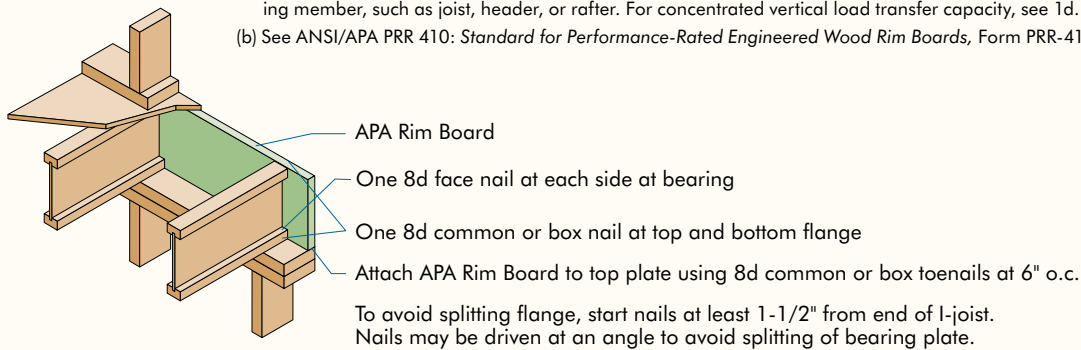

1c

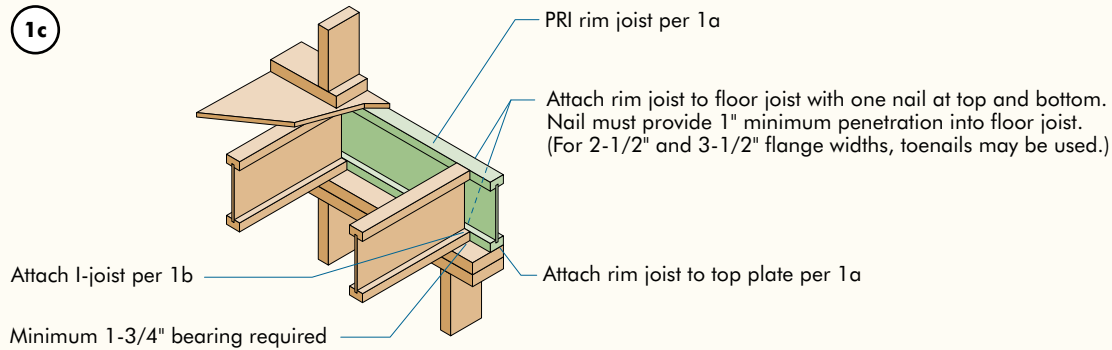

1d

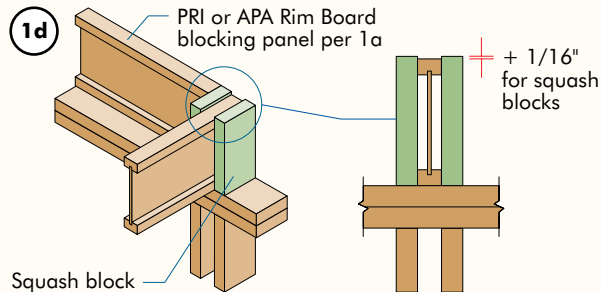

Pair of Squash Blocks	Vertical load transfer capacity per pair of squash blocks (lbf) ^(a)	
	3-1/2" wide	5-1/2" wide
2x lumber	3800	5900
1-1/8" APA Rim Board, Rim Board Plus, C1 or better ^(b) , or Rated Sturd-I-Floor 48 oc	2600	4000
1" APA Rim Board, C2 or better ^(b) , or Rated Sturd-I-Floor 32 oc	1900	3000

(a) The squash blocks are assumed to be in full bearing on the plate below.
 (b) See ANSI/APA PRR 410: *Standard for Performance-Rated Engineered Wood Rim Boards*, Form PRR-410.

All nails shown in the details above are assumed to be common nails unless otherwise noted. 10d box nails (0.128 inch x 3 inches) may be substituted for 8d common (0.131 inch x 2-1/2 inches) shown in details. Individual components not shown to scale for clarity.

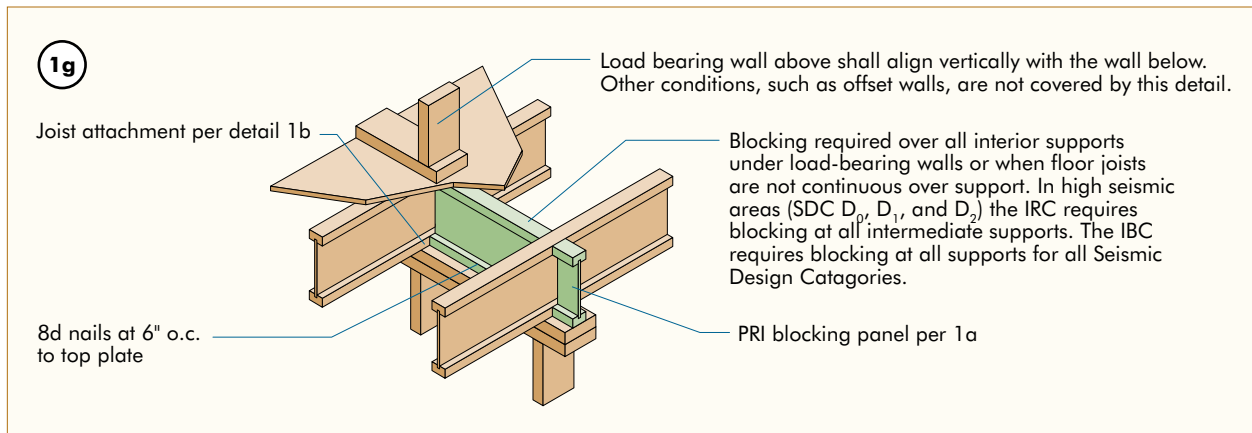
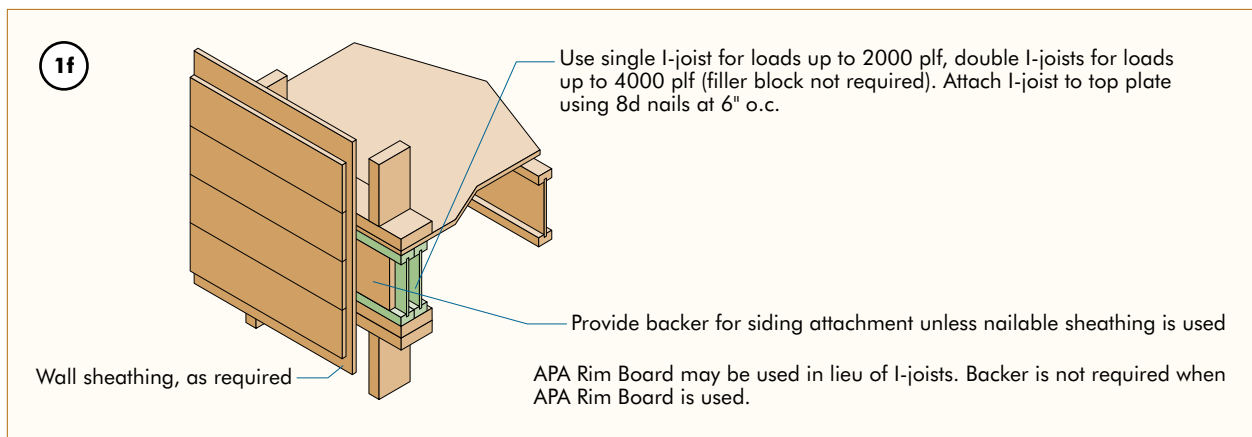
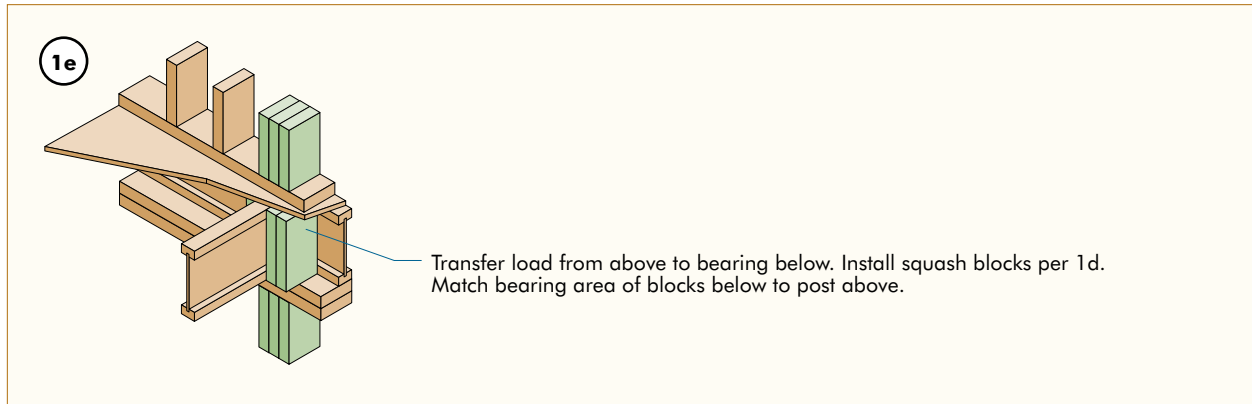

All nails shown in the details above are assumed to be common nails unless otherwise noted. 10d box nails (0.128 inch x 3 inches) may be substituted for 8d common (0.131 inch x 2-1/2 inches) shown in details. Individual components not shown to scale for clarity.

1h

Backer block (use if hanger load exceeds 250 lbf.)

Before installing a backer block to a double I-joist, drive 3 additional 10d nails through the webs and filler block where the backer block will fit. Clinch. Install backer tight to top flange. Use twelve 10d nails, clinched when possible. Maximum capacity for hanger for this detail = 1280 lbf.

BACKER BLOCKS (Blocks must be long enough to permit required nailing without splitting)

Flange Width	Material Thickness Required ^(a)	Minimum Depth ^(b)
1-1/2"	19/32"	5-1/2"
1-3/4"	23/32"	5-1/2"
2-5/16"	1"	7-1/4"
2-1/2"	1"	5-1/2"
3-1/2"	1-1/2"	7-1/4"

Notes:

(a) Minimum grade for backer block material shall be Utility grade SPF (south) or better for solid sawn lumber and Rated Sheathing or Single Floor grade for wood structural panels.

(b) For face-mount hangers use net joist depth minus 3-1/4" for joists with 1-1/2" thick flanges. For 1-5/16" thick flanges use net depth minus 2-7/8".

Top- or face-mounted hanger

Double I-joist header

Note: Unless hanger sides laterally support the top flange, bearing stiffeners shall be used.

Filler block per 1p

Backer block required (both sides for face-mounted hangers)

For hanger capacity see hanger manufacturer's recommendations. Verify double I-joist capacity to support concentrated loads.

1j

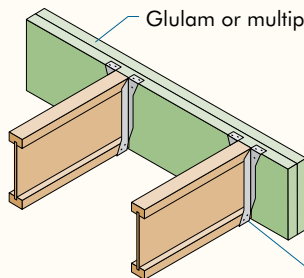

Glulam or multiple structural composite lumber (SCL) beams

For nailing schedules for multiple SCL beams, see the manufacturer's recommendations.

Top- or face-mounted hanger installed per manufacturer's recommendations

Unless hanger sides laterally support the top flange, bearing stiffeners shall be used.

1k

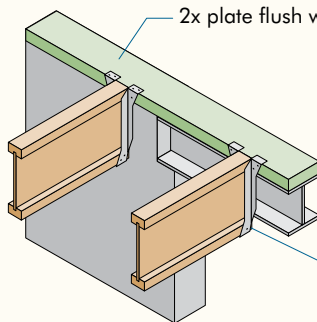

2x plate flush with inside face of wall or beam

Unless hanger sides laterally support the top flange, bearing stiffeners shall be used.

Top-mounted hanger installed per manufacturer's recommendations

All nails shown in the details above are assumed to be common nails unless otherwise noted. Individual components not shown to scale for clarity.

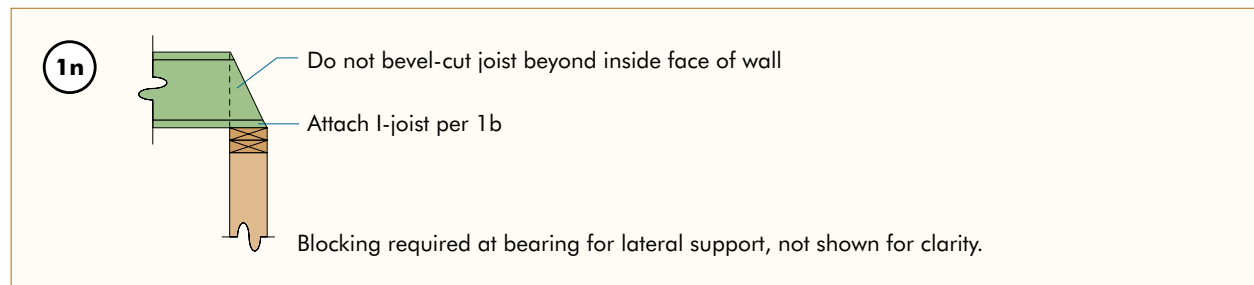
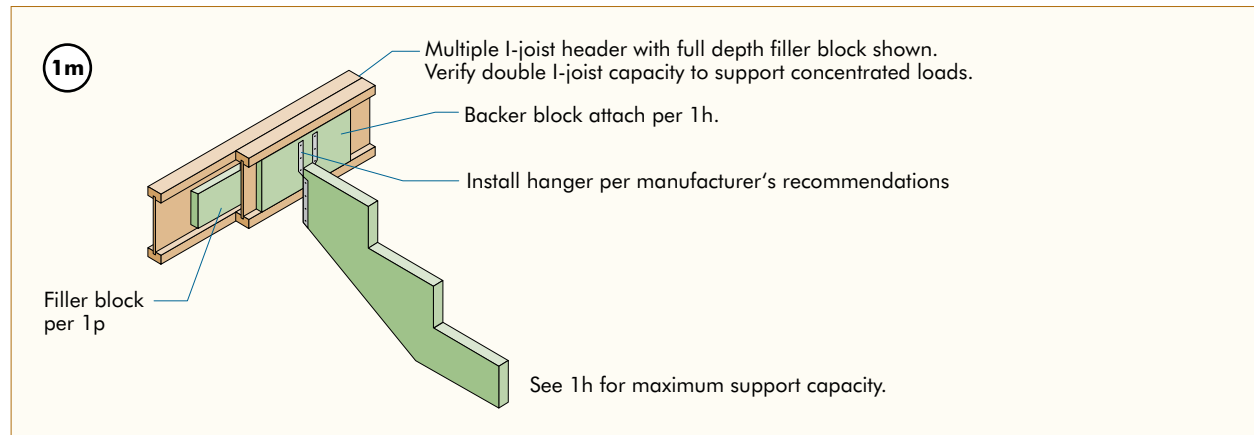

1p

Filler block

Offset nails from opposite face

1/8" to 1/4" gap between top flange and filler block

12"

FILLER BLOCK REQUIREMENTS FOR DOUBLE I-JOIST CONSTRUCTION

Flange Width	Net Depth	Filler Block Size
1-1/2"	9-1/2"	1-1/8" x 6" high
	11-7/8"	1-1/8" x 8" high
1-3/4"	9-1/2"	1-3/8" x 6"
	11-7/8"	1-3/8" x 8"
	14"	1-3/8" x 10"
2-5/16"	16"	1-3/8" x 12"
	11-7/8"	2" x 8"
2-1/2"	14"	2" x 10"
	16"	2" x 12"
	9-1/2"	2-1/8" x 6"
3-1/2"	11-7/8"	2-1/8" x 8"
	14"	2-1/8" x 10"
	16"	2-1/8" x 12"
3-1/2"	11-7/8"	3" x 8"
	14"	3" x 10"
	16"	3" x 12"

Notes:

1. Support back of I-joist web during nailing to prevent damage to web/flange connection.
2. Leave a 1/8-inch to 1/4-inch gap between top of filler block and bottom of top I-joist flange.
3. Filler block is required between joists for full length of span.
4. For flange widths of 2-1/2 inches or less, nail joists together with two rows of 10d nails at 12 inches o.c. (clinched when possible) on each side of the double I-joist (total 4 nails per foot). For flange widths greater than 2-1/2 inches, use two rows of 10d nails at 6 inches o.c. on each side of the double I-joist (total 8 nails per foot).
5. The maximum load that may be applied to one side of the double joist using this detail is 620 lbf/ft.

All nails shown in the details above are assumed to be common nails unless otherwise noted. Individual components not shown to scale for clarity.

I-JOIST WEB STIFFENERS

A web stiffener is a wood block that is used to reinforce the web of an I-joist at locations where:

- The webs of the I-joist are in jeopardy of buckling out of plane. This usually occurs in deeper I-joists.
- The webs of the I-joist are in jeopardy of “knifing” through the I-joist flanges. This can occur at any I-joist depth when the design reaction loads exceed a specific level.
- The I-joist is supported in a hanger and the sides of the hanger do not extend up to the top flange. With the top flange unsupported by the hanger sides, the joist may deflect laterally, putting a twist in the flange of the joist. The web stiffener supports the I-joist along a vertical axis as designed. (In this application, the web stiffener acts very much like a backer block.)

There are two kinds of web stiffeners: **bearing stiffeners** and **load stiffeners**. They are differentiated by the applied load and the location of the gap between the slightly undersized stiffener and the top or bottom flange. (See Figure 2.)

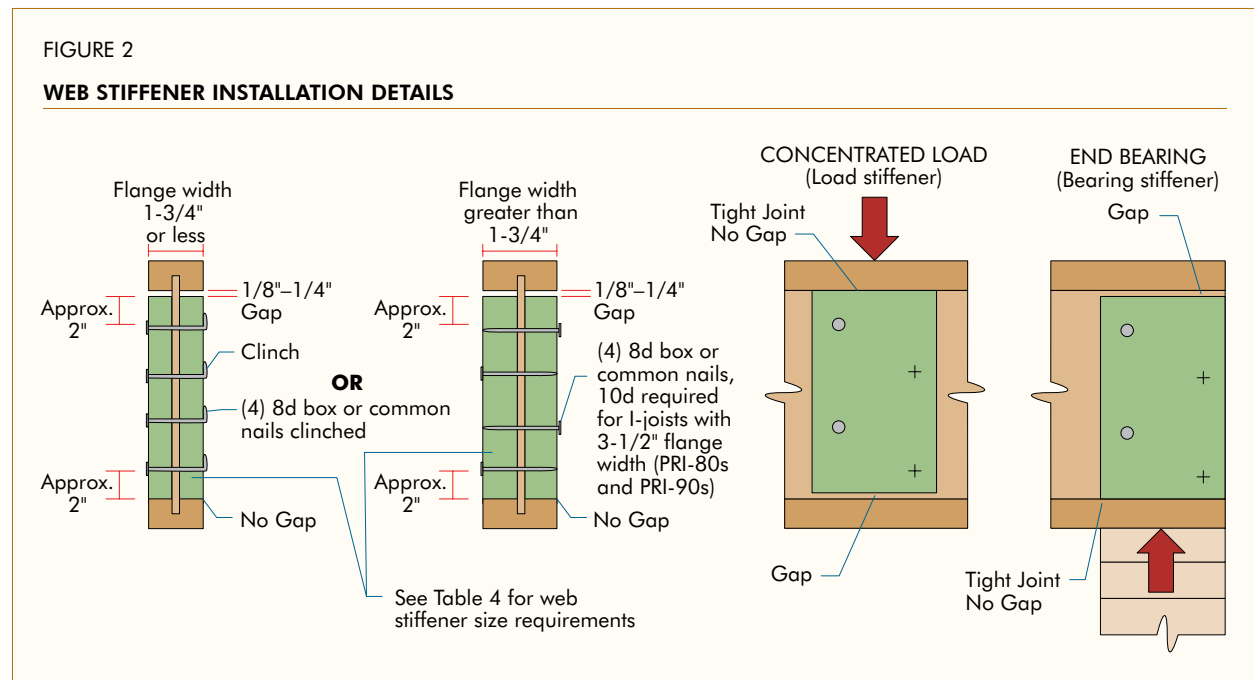

Bearing stiffeners are located at the reactions, both interior and exterior, when required.

Load stiffeners are located between supports where significant point loads are applied to the top flange of an I-joist.

Physical description:

Web stiffener blocks may be comprised of lumber, APA Rim Board or wood structural panels. The wood structural panels should be Rated Sheathing or Single Floor; minimum lumber grade is Utility grade SPF (south) or better.

Ideally, the depth of the web stiffener should equal the distance between the flanges of the joist minus 1/8 inch to 1/4 inch. For **bearing stiffeners**, this gap is placed between the top of the stiffener and the bottom of the top flange. For **load stiffeners**, the gap is located at the bottom of the stiffener.

TABLE 4

STIFFENER SIZE REQUIREMENTS

PRI Flange Width	Web Stiffener Size Each Side of Web
1-1/2"	15/32" x 2-5/16" minimum width
1-3/4"	19/32" x 2-5/16" minimum width
2-5/16"	1" x 2-5/16" minimum width
2-1/2"	1" x 2-5/16" minimum width
3-1/2"	1-1/2" x 2-5/16" minimum width

Recommendations for I-joists designed in accordance with APA Standard PRI-400:

1. A **bearing stiffener** is required in all engineered applications with design end reactions greater than 1,550 lbf, with the exception of PRI-90, which requires bearing stiffeners when end reaction values exceed 1,885 lbf. The gap between the stiffener and the flange is at the top.
2. A **bearing stiffener** is required when the I-joist is supported in a hanger and the sides of the hanger do not extend up to, and support, the top flange. The gap between the stiffener and flange is at the top.
3. A **load stiffener** is required at locations where a concentrated load greater than 1,500 lbf is applied to the top flange between supports, or in the case of a cantilever, anywhere between the cantilever tip and the support. These values are for normal duration of load, and may be adjusted for other load durations as permitted by the code. The gap between the stiffener and the flange is at the bottom.

Cantilever Details for Balconies (No Wall Load)

Balconies may be constructed using either continuous APA PRIs (Figure 3) or by adding lumber extensions (Figure 4) to the I-joist. Continuous I-joist cantilevers are limited to one-fourth the adjacent span when supporting uniform loads only. For applications supporting concentrated loads at the end of the cantilever, such as a wall, see Figures 5a, 5b, 5c and 5d.

Unless otherwise engineered, cantilevers are limited to a maximum of 4 feet when supporting uniform loads only. Blocking is required at the cantilever support, as shown.

Uniform floor load shall not exceed 40 psf live load and 10 psf dead load. The balcony load shall not exceed 60 psf live load and 10 psf dead load.

CAUTION: APA cantilevered balcony details address structural considerations only. Cantilevered balcony details for moisture control, weathering and durability are beyond the scope of this publication.

FIGURE 3

I-JOIST CANTILEVER DETAIL FOR BALCONIES

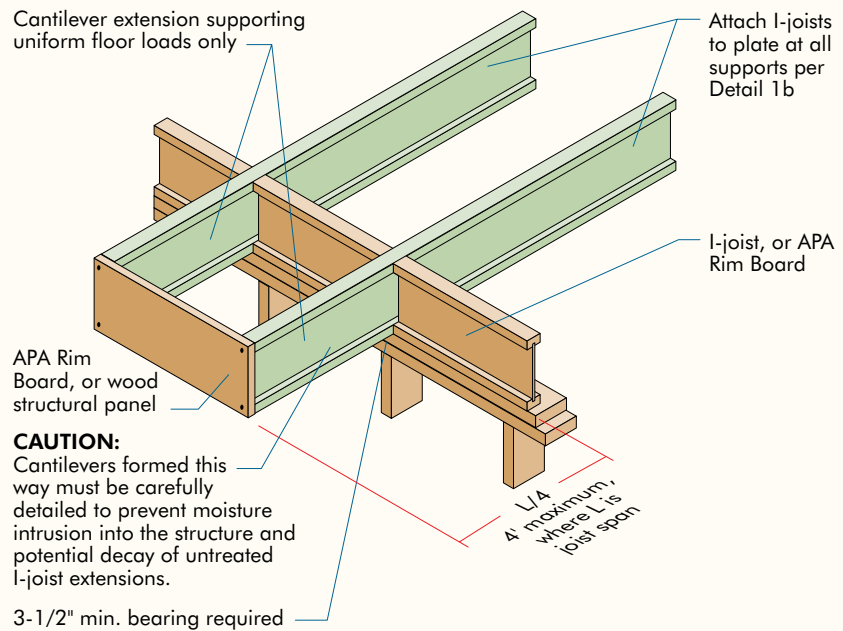
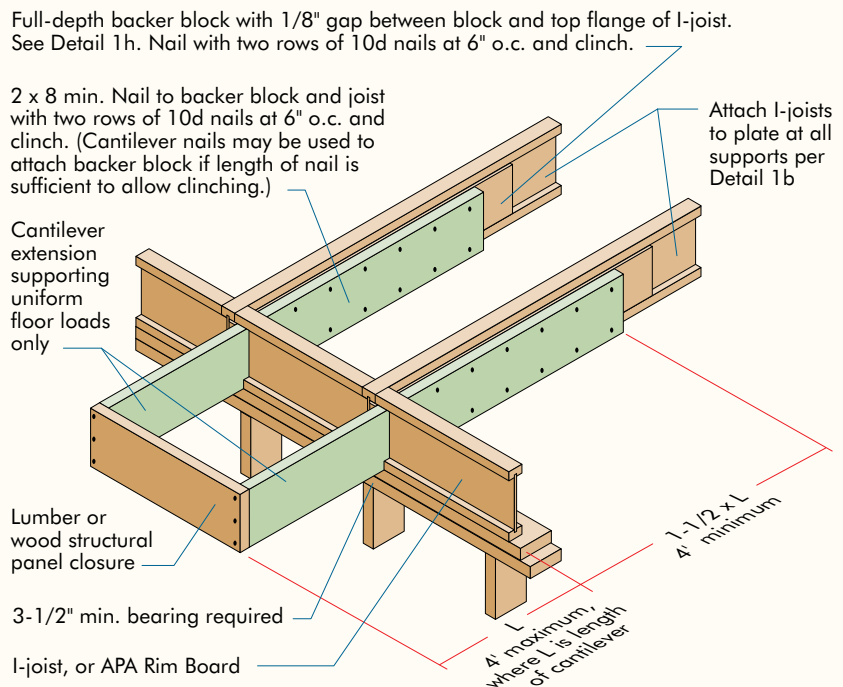

FIGURE 4

LUMBER CANTILEVER DETAIL FOR BALCONIES



All nails shown in the details above are assumed to be common nails unless otherwise noted. Individual components not shown to scale for clarity.

Cantilever Details for Vertical Building Offset (Uniform Wall Load)

I-joists may also be used in cantilever applications supporting a uniform wall load applied to the end of the cantilever, such as with a vertical building offset. For cantilever-end load applications that require reinforcing based on Table 5, the cantilever is limited to 2 feet maximum. In addition, blocking is required along the cantilever support and for 4 feet on each side of the cantilever area. Subject to the roof loads and layout (see Table 5), three methods of reinforcing are allowed in load bearing cantilever applications: reinforcing sheathing applied to one side of the I-joist (Method 1), reinforcing sheathing applied to both sides of the I-joist (Method 2) **or** double I-joists (Alternate Method 2).

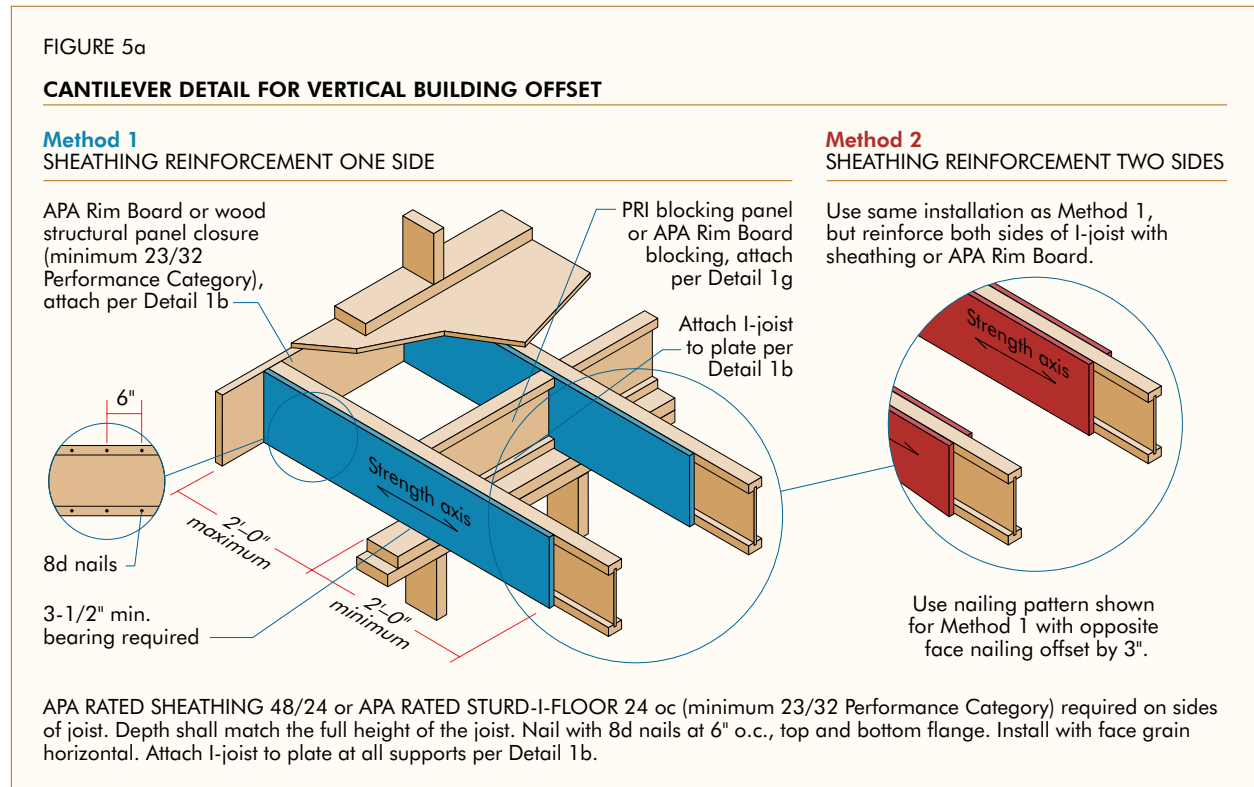

All nails shown in the details above are assumed to be common nails unless otherwise noted. Individual components not shown to scale for clarity.

FIGURE 5b

CANTILEVER DETAIL FOR VERTICAL BUILDING OFFSET

Alternate Method 2
DOUBLE I-JOIST

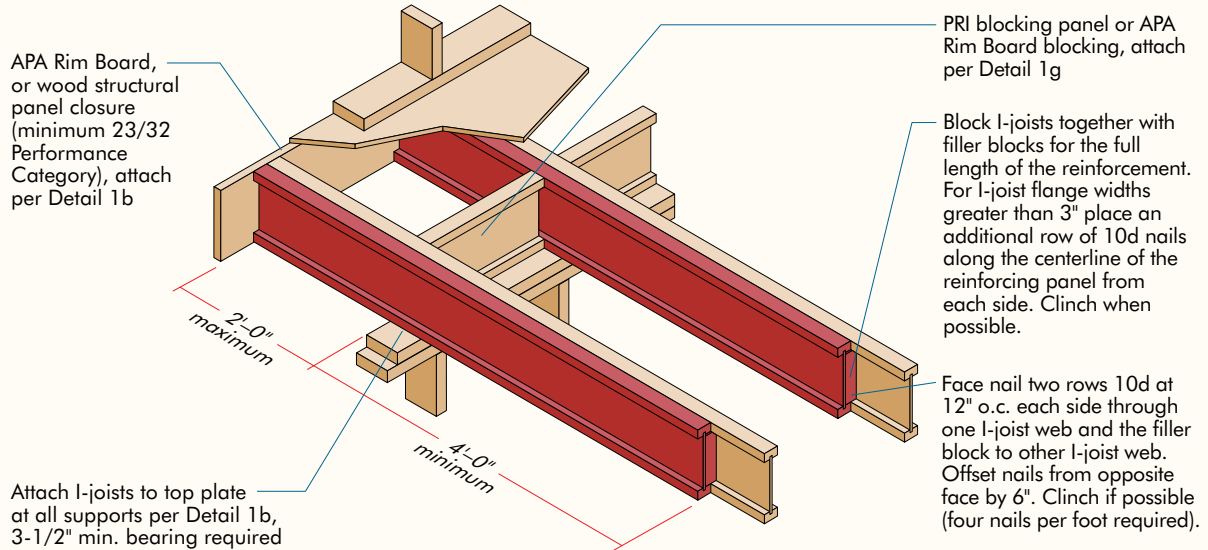

All nails shown in the details above are assumed to be common nails unless otherwise noted. Individual components not shown to scale for clarity.

FIGURE 5c

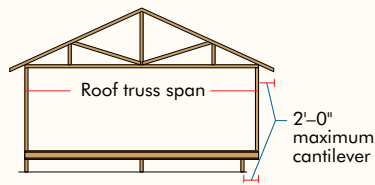

See Table 5 for APA PRI reinforcement requirements at cantilever.

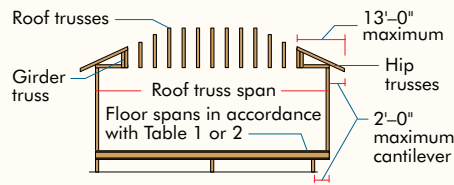

For hip roofs with the hip trusses running parallel to the cantilevered floor joists, the I-joist reinforcement requirements for a span of 26 ft shall be permitted to be used.

TABLE 5

PRI CANTILEVER REINFORCEMENT METHODS ALLOWED

Joist Depth (in.)	Roof Truss Span (ft)	Roof Loadings											
		TL = 35 psf LL not to exceed 20 psf				TL = 45 psf LL not to exceed 30 psf				TL = 55 psf LL not to exceed 40 psf			
		Joist Spacing (in.)				Joist Spacing (in.)				Joist Spacing (in.)			
		12	16	19.2	24	12	16	19.2	24	12	16	19.2	24
9-1/2	26	N	N	N	1	N	N	1	2	N	1	2	X
	28	N	N	N	1	N	N	1	2	N	1	2	X
	30	N	N	1	1	N	N	1	2	N	1	2	X
	32	N	N	1	2	N	1	1	X	N	1	2	X
	34	N	N	1	2	N	1	2	X	N	2	X	X
	36	N	N	1	2	N	1	2	X	N	2	X	X
11-7/8	26	N	N	N	1	N	N	1	1	N	1	1	2
	28	N	N	1	1	N	1	1	1	N	1	1	2
	30	N	N	1	1	N	1	1	2	N	1	1	2
	32	N	N	1	1	N	1	1	2	N	1	1	2
	34	N	N	1	1	N	1	1	2	N	1	2	2
	36	N	N	1	1	N	1	1	2	N	1	2	2
14	38	N	1	1	2	N	1	1	2	1	1	2	X
	26	N	N	N	1	N	N	N	1	N	N	1	1
	28	N	N	N	1	N	N	1	1	N	N	1	2
	30	N	N	N	1	N	N	1	1	N	1	1	2
	32	N	N	N	1	N	N	1	1	N	1	1	2
	34	N	N	N	1	N	N	1	2	N	1	1	2
16	36	N	N	1	1	N	1	1	2	N	1	1	2
	38	N	N	1	1	N	1	1	2	N	1	1	2
	26	N	N	N	1	N	N	1	1	N	N	1	1
	28	N	N	N	1	N	N	1	1	N	N	1	2
	30	N	N	N	1	N	N	1	1	N	1	1	2
	32	N	N	N	1	N	N	1	1	N	1	1	2
16	34	N	N	1	1	N	N	1	2	N	1	1	2
	36	N	N	1	1	N	1	1	2	N	1	1	2
	38	N	N	1	1	N	1	1	2	N	1	1	2
	40	N	N	1	1	N	1	1	2	N	1	2	2
	42	N	N	1	1	N	1	1	2	N	1	2	X

Notes:

- (1) N = No reinforcement required.
 - 1 = PRIs reinforced with 23/32 Performance Category wood structural panel on one side only.
 - 2 = PRIs reinforced with 23/32 Performance Category wood structural panel on both sides or double I-joist.
 - X = Try a deeper joist or closer spacing.
- (2) Color coding in table is matched to details in Figure 5a and 5b.
- (3) Maximum load shall be: 15 psf roof dead load, 50 psf floor total load, and 80 plf wall load. Wall load is based on 3'-0" maximum width window or door openings. For larger openings, or multiple 3'-0" width openings spaced less than 6'-0" o.c., additional joists beneath the opening's cripple studs may be required.
- (4) Table applies to joists 12" to 24" o.c. Use 12" o.c. requirements for lesser spacings.
- (5) For conventional roof construction using a ridge beam, the Roof Truss Span column above is equivalent to the distance between the supporting wall and the ridge beam. When the roof is framed using a ridge board, the Roof Truss Span is equivalent to the distance between the supporting walls as if a truss is used.

Short Cantilever

For uniform wall loads acting at the end of very short cantilevers (5-1/2 inches maximum), consult the detail shown in Figure 5d. This figure is based on the 2015 International Residential Code (IRC) Sections R301.2.2.2.5, R602.10, and R602.11, and Table R602.3(1). In this detail, the I-joist does not need to be reinforced. Note that the 2015 IRC provides other equivalent fastening options for many of the fastening details shown in Figure 5d.

FIGURE 5d

DETAIL FOR SHORT CANTILEVER

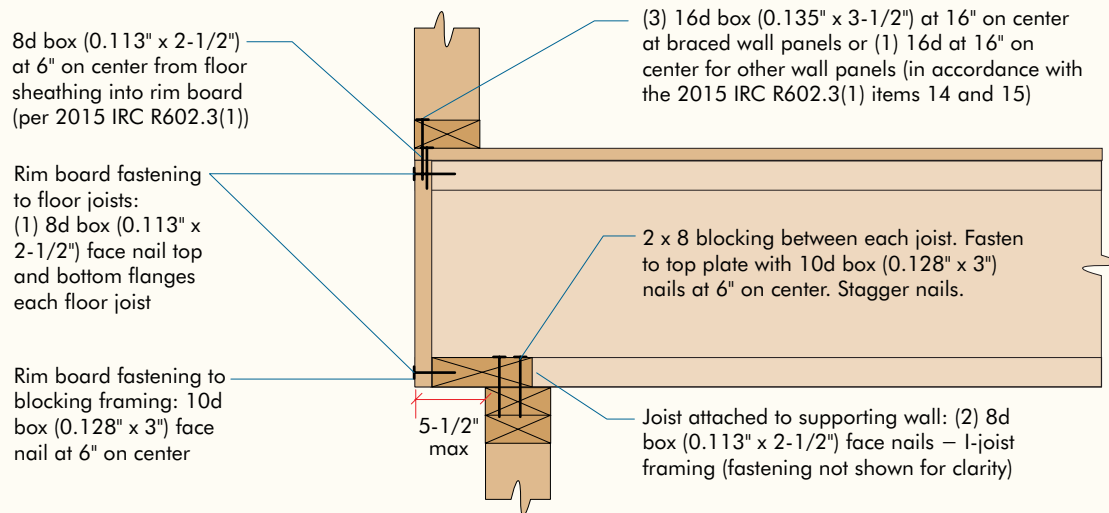

Notes:

1. The 2015 International Residential Code (IRC) provides multiple fastening options. Fastening options used above reflect most common applications.
2. The above detail is appropriate for one- and two-family residential structures constructed in accordance with the 2015 (IRC) Sections R301.2.2.2.5 and R602.10, and Table R602.3(1).
3. Cantilevered joists must be properly sized to support all design loads.
4. Applications that fall outside of the scope of the 2015 IRC shall be designed in accordance with the 2015 International Building Code (IBC).

WEB HOLE SPECIFICATIONS

One of the benefits of using I-joists in residential floor construction is that holes may be cut in the joist webs to accommodate electrical wiring, plumbing lines and other mechanical systems, therefore minimizing the depth of the floor system.

Rules for cutting holes in PRI Joists

1. The distance between the inside edge of the support and the centerline of any hole shall be in compliance with the requirements of Table 6.
2. I-joist top and bottom flanges must **never** be cut, notched or otherwise modified.
3. Whenever possible, field-cut holes should be centered on the middle of the web.
4. The maximum size hole that can be cut into an I-joist web shall equal the clear distance between the flanges of the I-joist minus 1/4 inch. A minimum of 1/8 inch should always be maintained between the top or bottom of the hole and the adjacent I-joist flange.
5. The sides of square holes or longest sides of rectangular holes should not exceed three-fourths of the diameter of the maximum round hole permitted at that location.
6. Where more than one hole is necessary, the distance between adjacent hole edges shall exceed twice the diameter of the largest round hole or twice the size of the largest square hole (*or twice the length of the longest side of the longest rectangular hole*) and each hole must be sized and located in compliance with the requirements of Table 6.
7. A knockout is **not** considered a hole, may be utilized anywhere it occurs, and may be ignored for purposes of calculating minimum distances between holes.
8. Holes measuring 1-1/2 inches or smaller shall be permitted anywhere in a cantilevered section of a PRI Joist. Holes of greater size may be permitted subject to verification.
9. A 1-1/2-inch hole or smaller can be placed anywhere in the web provided that it meets the requirements of rule number 6 above.
10. All holes shall be cut in accordance with the restrictions listed above and as illustrated in Figure 6.
11. Limit three maximum-size holes per span.
12. A group of round holes at approximately the same location shall be permitted if they meet the requirements for a single round hole circumscribed around them.

FIGURE 6

PRI JOIST TYPICAL HOLES

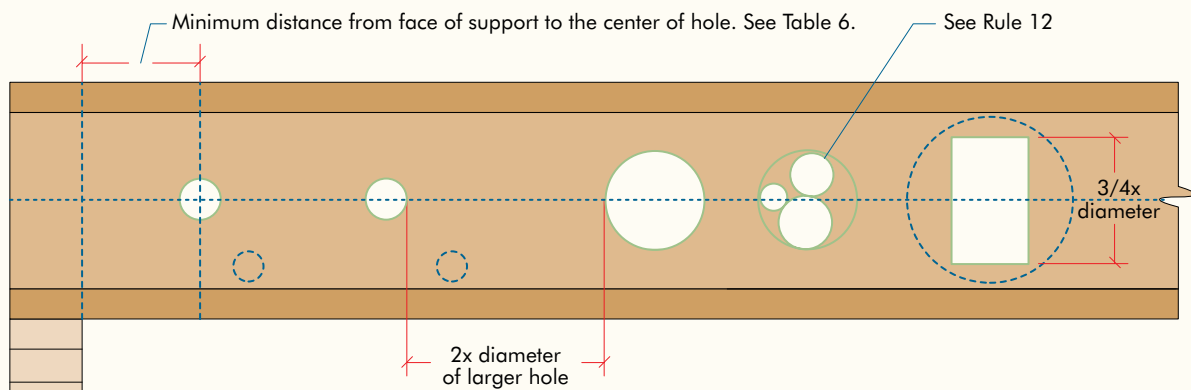

Knockouts are prescored holes often provided by I-joist manufacturers for the contractor's convenience to install electrical or small plumbing lines. They are typically 1-3/8 to 1-3/4 inches in diameter, and are spaced 12 to 24 inches on center along the length of the I-joist. Where possible, it is preferable to use knockouts instead of field-cutting holes.

Cutting the Hole

- Never drill, cut or notch the flange, or over-cut the web.
- Holes in webs should be cut with a sharp saw.
- For rectangular holes, avoid over-cutting the corners, as this can cause unnecessary stress concentrations. Slightly rounding the corners is recommended. Starting the rectangular hole by drilling a 1-inch-diameter hole in each of the four corners and then making the cuts between the holes is another good method to minimize damage to the I-joist.

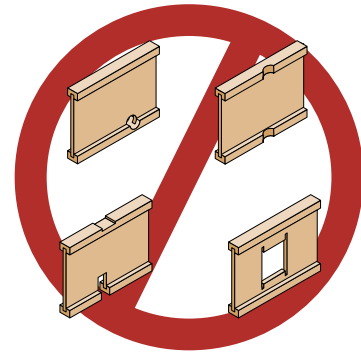

TABLE 6

LOCATION OF CIRCULAR HOLES IN PRI JOIST WEBS

Simple or Multiple Span for Dead Loads up to 10 psf and Live Loads up to 40 psf^{(a)(b)(c)(d)}

Joist Depth	Series	SAF ^(e)	Minimum Distance from Inside Face of Any Support to Center of Hole (ft.-in.)														
			Round Hole Diameter (in.)														
			2	3	4	5	6	6-1/4	7	8	8-5/8	9	10	10-3/4	11	12	12-3/4
9-1/2"	PRI-20	13'-1"	0'-7"	0'-11"	2'-2"	3'-6"	5'-0"	5'-5"									
	PRI-30	13'-9"	0'-9"	2'-0"	3'-3"	4'-7"	6'-1"	6'-6"									
	PRI-40	14'-4"	0'-7"	1'-8"	3'-0"	4'-4"	5'-9"	6'-3"									
	PRI-50	14'-5"	1'-1"	2'-4"	3'-8"	5'-0"	6'-6"	6'-11"									
	PRI-60	15'-0"	1'-7"	2'-10"	4'-2"	5'-7"	7'-1"	7'-6"									
11-7/8"	PRI-20	13'-5"	0'-7"	0'-8"	0'-8"	0'-9"	1'-11"	2'-4"	3'-7"	5'-8"	7'-0"						
	PRI-30	15'-0"	0'-7"	0'-8"	0'-8"	1'-9"	3'-4"	3'-9"	5'-0"	6'-10"	8'-0"						
	PRI-40	16'-7"	0'-7"	0'-8"	1'-2"	2'-5"	3'-9"	4'-1"	5'-1"	6'-8"	7'-11"						
	PRI-50	16'-1"	0'-7"	0'-8"	0'-11"	2'-5"	4'-1"	4'-6"	5'-9"	7'-7"	8'-10"						
	PRI-60	17'-10"	0'-7"	1'-9"	3'-0"	4'-4"	5'-9"	6'-1"	7'-2"	8'-9"	9'-10"						
	PRI-70	18'-5"	0'-7"	1'-2"	2'-5"	3'-9"	5'-2"	5'-7"	6'-11"	8'-10"	10'-1"						
	PRI-80	19'-7"	1'-8"	3'-0"	4'-3"	5'-7"	7'-1"	7'-5"	8'-7"	10'-2"	11'-4"						
	PRI-90	20'-2"	0'-7"	0'-8"	1'-1"	2'-9"	4'-6"	5'-0"	6'-5"	8'-5"	9'-9"						
14"	PRI-40	18'-3"	0'-7"	0'-8"	0'-8"	0'-9"	1'-10"	2'-2"	3'-2"	4'-7"	5'-5"	6'-0"	7'-7"	9'-4"			
	PRI-50	16'-1"	0'-7"	0'-8"	0'-8"	0'-9"	0'-9"	1'-0"	2'-5"	4'-4"	5'-7"	6'-5"	8'-7"	10'-5"			
	PRI-60	19'-9"	0'-7"	0'-8"	0'-8"	1'-7"	2'-10"	3'-3"	4'-6"	6'-3"	7'-4"	8'-1"	10'-0"	11'-8"			
	PRI-70	18'-6"	0'-7"	0'-8"	0'-8"	0'-11"	2'-6"	2'-11"	4'-2"	5'-11"	7'-0"	7'-10"	10'-1"	12'-0"			
	PRI-80	22'-2"	0'-7"	1'-9"	3'-0"	4'-4"	5'-8"	6'-1"	7'-1"	8'-7"	9'-7"	10'-3"	11'-11"	13'-5"			
	PRI-90	22'-10"	0'-7"	0'-8"	0'-8"	2'-1"	3'-8"	4'-1"	5'-4"	7'-1"	8'-3"	9'-0"	11'-0"	12'-7"			
16"	PRI-40	19'-8"	0'-7"	0'-8"	0'-8"	0'-9"	0'-9"	0'-10"	1'-5"	2'-9"	3'-7"	4'-1"	5'-6"	6'-7"	7'-0"	8'-9"	10'-9"
	PRI-50	16'-1"	0'-7"	0'-8"	0'-8"	0'-9"	0'-9"	0'-10"	0'-10"	0'-10"	1'-9"	2'-6"	4'-6"	6'-0"	6'-7"	9'-3"	11'-7"
	PRI-60	19'-9"	0'-7"	0'-8"	0'-8"	0'-9"	0'-9"	0'-10"	1'-10"	3'-6"	4'-6"	5'-2"	6'-11"	8'-6"	9'-1"	11'-5"	13'-4"
	PRI-70	18'-6"	0'-7"	0'-8"	0'-8"	0'-9"	0'-9"	0'-10"	1'-0"	2'-11"	4'-1"	4'-10"	6'-11"	8'-7"	9'-1"	11'-6"	13'-5"
	PRI-80	23'-11"	0'-7"	0'-8"	0'-8"	1'-7"	2'-11"	3'-3"	4'-6"	6'-2"	7'-3"	7'-11"	9'-9"	11'-3"	11'-9"	13'-11"	15'-7"
	PRI-90	25'-3"	0'-7"	0'-8"	0'-8"	0'-10"	2'-3"	2'-8"	3'-10"	5'-5"	6'-5"	7'-1"	8'-10"	10'-2"	10'-8"	12'-11"	14'-10"

Notes:

- (a) Above tables may be used for I-joist spacing of 24 inches o.c. or less.
- (b) Hole location distance is measured from inside face of supports to center of hole.
- (c) Distances in this chart are based on uniformly loaded joists.
- (d) Hole sizes and/or locations that fall outside the scope of this table may be acceptable based on analysis of actual hole size, span, spacing and loading conditions. The I-joist shear capacity at the location of a circular web hole (V_{nh}) is calculated using the following equation:

$$V_{nh} = \text{Published Shear Value} \times [(Joist\ Depth - Hole\ Diameter) / Joist\ Depth]$$

- (e) SAF = Span Adjustment Factor, used as defined below:

OPTIONAL:

Table 6 is based on the I-joists used at their maximum span. If the I-joists are placed at less than their full allowable span, the maximum distance from the centerline of the hole to the face of any support (D) as given above may be reduced as follows:

$$D_{reduced} = \frac{L_{actual}}{SAF} \times D$$

Where: $D_{reduced}$ = Distance from the inside face of any support to center of hole, reduced for less-than-maximum span applications (ft). The reduced distance shall not be less than 6 inches from the face of the support to edge of the hole.

L_{actual} = The actual measured span distance between the inside faces of supports (ft).

SAF = Span Adjustment Factor given in this table.

D = The minimum distance from the inside face of any support to center of hole from this table.

If $\frac{L_{actual}}{SAF}$ is greater than 1, use 1 in the above calculation for $\frac{L_{actual}}{SAF}$

RIM BOARD HOLE SPECIFICATIONS

The maximum allowable hole size for an APA Rim Board shall be $\frac{2}{3}$ of the Rim Board depth, as shown in Table 7. The length of the Rim Board segment containing a hole shall be at least eight times the hole size.

TABLE 7

RIM BOARD HOLE SIZES AND MINIMUM LENGTH

Rim Board Depth (in.)	Maximum Allowable Hole Size ^{(a)(b)} (in.)	Minimum Length of Rim Board Segment ^(c) for the Maximum Allowable Hole Size (in.)
9-1/2	6-1/4	50
11-7/8	7-3/4	62
14	9-1/4	74
16	10-1/2	84

(a) These hole provisions do not apply to Rim Board installed over openings, such as doors or windows.

(b) The diameter of a round hole or the longer dimension of a rectangular hole.

(c) The length of Rim Board segment per wall line. For multiple holes, the minimum length of Rim Board segment shall be eight times the sum of all hole sizes.

Application Notes

- Do not cut holes in Rim Board installed over openings, such as doors or windows, where the Rim Board is not fully supported, except that holes of 1-1/2 inches or less in size are permitted provided they are positioned at the mid-depth and in the middle one-third of the span (see Note 5 for minimum hole spacing).

FIGURE 7

RIM BOARD OVER AN OPENING

Do not cut holes in Rim Board over opening except for holes of 1-1/2" or less in size (see Application Note 1).

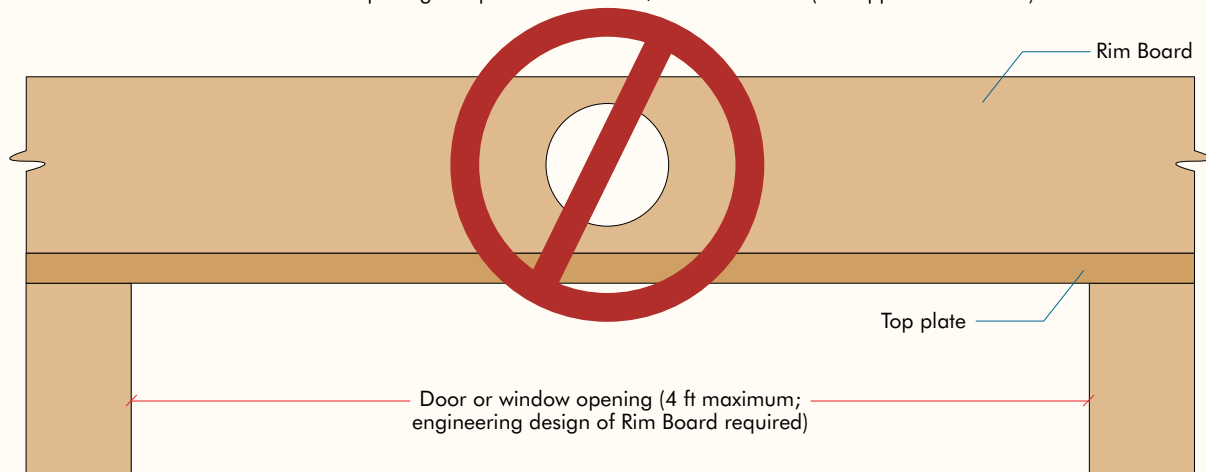

- Field-cut holes should be vertically centered in the Rim Board and at least one hole diameter or 6 inches, whichever is less, clear distance away from the end of the wall line. Holes should never be placed such that they interfere with the attachment of the Rim Board to the ends of the floor joist, or any other code-required nailing.

3. While round holes are preferred, rectangular holes may be used providing the corners are not over-cut. Slightly rounding corners by pre-drilling with a 1-inch-diameter bit is recommended.
4. When concentrated loads are present on the Rim Board (loads not supported by any other vertical-load-carrying members such as squash blocks), holes should not be placed in the Rim Board within a distance equal to the depth of the Rim Board from the area of loading.

FIGURE 8

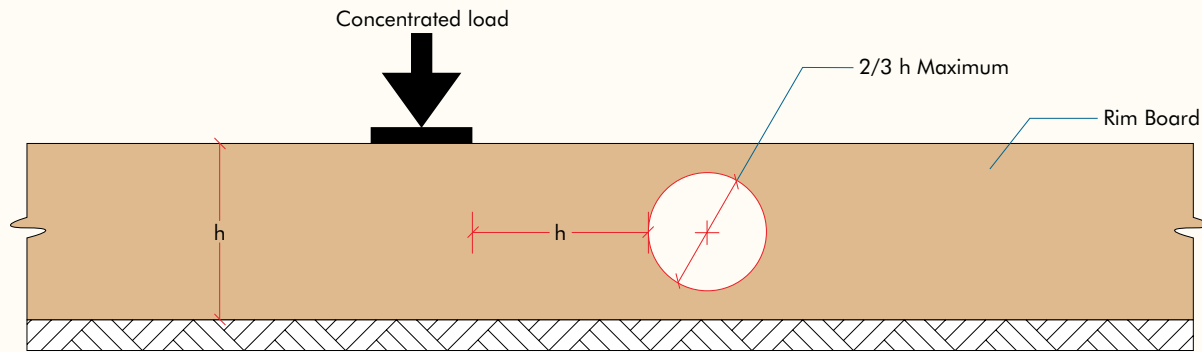
RIM BOARD NEAR CONCENTRATED VERTICAL LOAD

5. For multiple holes, the clear spacing between holes shall be at least two times the diameter of the larger hole, or twice the length of the longest side of the longest rectangular hole. This minimum hole spacing does not apply to holes of 1-1/2 inches or less in diameter, which can be placed anywhere in the Rim Board (see Note 1 for holes over opening) except that the clear distance to the adjacent hole shall be 3 inches minimum.
6. All holes shall be cut in accordance with the limitations listed above. See the information for cutting holes under Figure 6.

FIGURE 9

MULTIPLE HOLES FOR RIM BOARD

TABLE 8

DESIGN PROPERTIES FOR APA EWS PERFORMANCE-RATED I-JOISTS^(a)

Depth	Joist Series	EI ^(b) 10 ⁶ lbf-in. ²	M ^(c) lbf-ft	V ^(d) lbf	IR ^(e,i) lbf	ER ^(f,i) lbf				VLC ^(g) lbf/ft	K ^(h) 10 ⁶ lbf
						1-3/4" Brg w/o Stiffeners	1-3/4" Brg w/ Stiffeners	4" Brg w/o Stiffeners	4" Brg w/ Stiffeners		
9-1/2"	PRI-20	132	2,520	1,120	1,700	830	830	1,120	1,120	2,000	4.94
	PRI-30	159	3,225	1,120	1,905	945	945	1,120	1,120	2,000	4.94
	PRI-40	184	2,735	1,120	2,160	1,080	1,080	1,120	1,120	2,000	4.94
	PRI-50	186	3,800	1,120	2,040	1,015	1,015	1,120	1,120	2,000	4.94
	PRI-60	219	3,780	1,120	2,160	1,080	1,080	1,120	1,120	2,000	4.94
11-7/8"	PRI-20	225	3,265	1,420	1,700	830	830	1,420	1,420	2,000	6.18
	PRI-30	271	4,170	1,420	1,905	945	945	1,420	1,420	2,000	6.18
	PRI-40	313	3,545	1,420	2,500	1,200	1,200	1,420	1,420	2,000	6.18
	PRI-50	316	4,915	1,420	2,040	1,015	1,015	1,420	1,420	2,000	6.18
	PRI-60	371	4,900	1,420	2,500	1,200	1,200	1,420	1,420	2,000	6.18
	PRI-70	416	6,595	1,420	2,335	1,160	1,160	1,420	1,420	2,000	6.18
	PRI-80	518	6,940	1,420	2,760	1,280	1,280	1,420	1,420	2,000	6.18
PRI-90	571	8,770	1,925	3,355	1,400	1,400	1,885	1,925	2,000	6.18	
14"	PRI-40	459	4,270	1,710	2,500	1,200	1,200	1,550	1,710	2,000	7.28
	PRI-50	463	5,860	1,710	2,040	1,015	1,015	1,550	1,710	2,000	7.28
	PRI-60	544	5,895	1,710	2,500	1,200	1,200	1,550	1,710	2,000	7.28
	PRI-70	609	7,865	1,710	2,335	1,160	1,160	1,550	1,710	2,000	7.28
	PRI-80	756	8,360	1,710	3,020	1,280	1,280	1,550	1,710	2,000	7.28
PRI-90	832	10,460	2,125	3,355	1,400	1,400	1,885	2,125	2,000	7.28	
16"	PRI-40	625	4,950	1,970	2,500	1,200	1,200	1,550	1,970	2,000	8.32
	PRI-50	630	6,715	1,970	2,040	1,015	1,015	1,550	1,970	2,000	8.32
	PRI-60	739	6,835	1,970	2,500	1,200	1,200	1,550	1,970	2,000	8.32
	PRI-70	826	9,010	1,970	2,335	1,160	1,160	1,550	1,970	2,000	8.32
	PRI-80	1,024	9,690	1,970	3,020	1,280	1,280	1,550	1,970	2,000	8.32
	PRI-90	1,126	11,985	2,330	3,355	1,400	1,400	1,885	2,330	2,000	8.32

Notes:

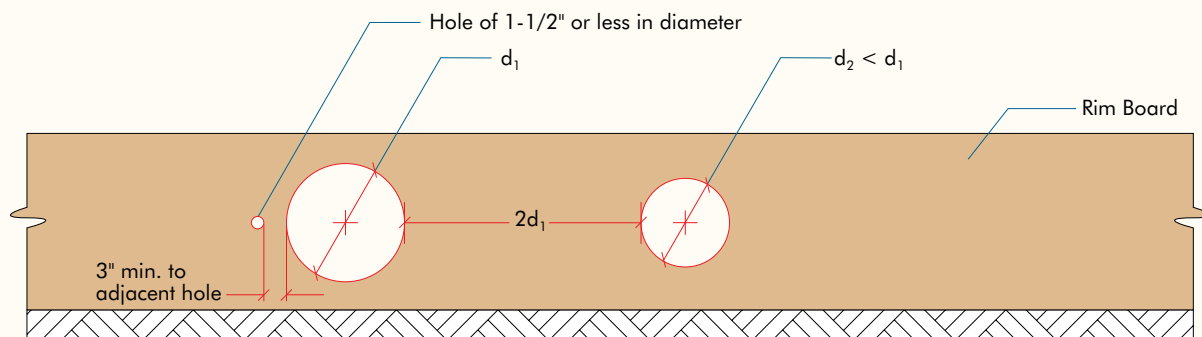
- (a) The tabulated values are design values for normal duration of load (10 years). All values, except for EI and K, shall be permitted to be adjusted for other load durations as permitted by the code, and the VLC values shall not be increased for shorter durations.
- (b) Bending stiffness (EI) of the I-joist.
- (c) Moment capacity (M) of the I-joist.
- (d) Shear capacity (V) of the I-joist.
- (e) Intermediate reaction (IR) of the I-joist with a minimum bearing length of 3-1/2 inches without bearing stiffeners.
- (f) End reaction (ER) of the I-joist. Interpolation between 1-3/4-in. and 4-in. bearings is permitted with or without bearing stiffeners.
- (g) Uniform vertical (bearing) load capacity (VLC).
- (h) Coefficient of shear deflection (K). For calculating uniform load and center-point load deflections of the I-joist in a simple-span application, use Eqs. 1 and 2.

$$\text{Uniform Load: } \delta = \frac{5\omega\ell^4}{384EI} + \frac{\omega\ell^2}{K} \quad [1]$$

$$\text{Center-Point Load: } \delta = \frac{P\ell^3}{48EI} + \frac{2P\ell}{K} \quad [2]$$

Where: δ = calculated deflection (in.), K = coefficient of shear deflection (lbf).
 P = concentrated load (lbf), ω = uniform load (lbf/in.),
 EI = bending stiffness of the I-joist (lbf-in.²), and ℓ = design span (in.).

- (i) The IR and ER design values after being adjusted for load duration shall meet the requirement given in Eq. 3.
 $ER \times C_D$ or $IR \times C_D$ (lbf) $\leq C_b b_{brg} L_{brg} F_{cl}$, or the capacity of the bearing plate supporting the I-joist (lbf), whichever is smaller [3]

Where: C_D = Load duration factor for ER and IR in accordance with the applicable code, b_{brg} = Bearing width of the I-joist = typically the flange width (b_f) minus 0.15 in. due to edge easing, (in.),
 C_b = Bearing area factor as defined in Section 3.10.4 of the NDS (= 1.0 for end reaction), L_{brg} = Bearing length of the I-joist (in.), and
 F_{cl} = Compressive stress perpendicular to grain of the I-joist flanges (lbf/in.²).

Note (Non-mandatory, for information only): Examples of PRI flange width and F_{cl} are listed below for reference. Refer to the manufacturer for specific flange widths and F_{cl} values as needed.

Series	Flange width b_{brg} , in.	F_{cl} , lbf/in. ²	Series	Flange width b_{brg} , in.	F_{cl} , lbf/in. ²
PRI-20 & PRI-30	1-1/2	450	PRI-70	2-5/16	450
PRI-40 & PRI-60	2-1/2	425	PRI-80	3-1/2	425
PRI-50	1-3/4	450	PRI-90	3-1/2	450

ABOUT APA

APA is a nonprofit trade association of and for structural wood panel, glulam timber, wood I-joist, structural composite lumber, and other engineered wood product manufacturers. Based in Tacoma, Washington, APA represents approximately 160 mills throughout North America, ranging from small, independently owned and operated companies to large integrated corporations.

Always insist on panels bearing the mark of quality—the APA trademark. Your APA panel purchase is not only your highest possible assurance of product quality, but an investment in the many trade services that APA provides on your behalf. The Association’s trademark appears only on products manufactured by member mills and is the manufacturer’s assurance that the product conforms to the standard shown on the trademark. That standard may be an APA performance standard, the Voluntary Product Standard PS 1-09 for Structural Plywood or Voluntary Product Standard PS 2-10, Performance Standard for Wood-Based Structural-Use Panels. Panel quality of all APA trademarked products is subject to verification through APA audit.

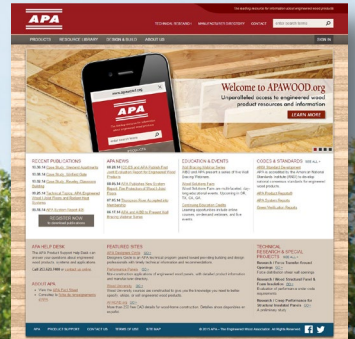
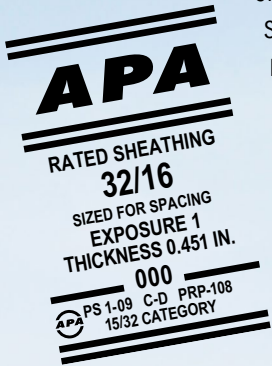

Performance Rated I-Joists

We have field representatives in many major U.S. cities and in Canada who can help answer questions involving APA trademarked products. For additional assistance in specifying engineered wood products, contact us:

APA HEADQUARTERS

7011 So. 19th St. ■ Tacoma, Washington 98466
(253) 565-6600 ■ Fax: (253) 565-7265

PRODUCT SUPPORT HELP DESK

(253) 620-7400 ■ help@apawood.org

DISCLAIMER

The information contained herein is based on APA – The Engineered Wood Association’s continuing programs of laboratory testing, product research, and comprehensive field experience. Neither APA, nor its members make any warranty, expressed or implied, or assume any legal liability or responsibility for the use, application of, and/or reference to opinions, findings, conclusions, or recommendations included in this publication. Consult your local jurisdiction or design professional to assure compliance with code, construction, and performance requirements. Because APA has no control over quality of workmanship or the conditions under which engineered wood products are used, it cannot accept responsibility for product performance or designs as actually constructed.



Form No. Z725F/Revised August 2015



REPRESENTING THE ENGINEERED WOOD INDUSTRY